

# VENTILATORI AC

AC FANS | VENTILATEURS AC



**PARTNERS**

**KAKU®**

**INDICE** Index | Index

**AC FAN 80x80x25**

AC FAN 80x80x25 | AC FAN 80x80x25

**AC FAN 80x80x38**

AC FAN 80x80x38 | AC FAN 80x80x38

**AC FAN 92x92x25**

AC FAN 92x92x25 | AC FAN 92x92x25

**AC FAN 92x92x38**

AC FAN 92x92x38 | AC FAN 92x92x38

**AC FAN 120x120x25**

AC FAN 120x120x25 | AC FAN 120x120x25

**AC FAN 120x120x38**

AC FAN 120x120x38 | AC FAN 120x120x38

**AC FAN 127x127x38**

AC FAN 127x127x38 | AC FAN 127x127x38

**AC FAN 150x150x51**

AC FAN 150x150x51 | AC FAN 150x150x51

**AC FAN 160x160x65**

AC FAN 160x160x65 | AC FAN 160x160x65

**AC FAN 180x180x65**

AC FAN 180x180x65 | AC FAN 180x180x65

**AC FAN 208x208x72**

AC FAN 208x208x72 | AC FAN 208x208x72

**AC FAN 172x152x38**

AC FAN 172x152x38 | AC FAN 172x152x38

**AC FAN 172x150x51**

AC FAN 172x150x51 | AC FAN 172x150x51

**AC FAN 172x150x55**

AC FAN 172x150x55 | AC FAN 172x150x55

**AC FAN 172x55**

AC FAN 172x55 | AC FAN 172x55

**AC FAN 222x60**

AC FAN 222x60 | AC FAN 222x60

**AC FAN 254x89**

AC FAN 254x89 | AC FAN 254x89



## INFORMAZIONI GENERALI | General Information | Informations Générales

### CLASSI DI PROTEZIONE

Sono disponibili ventilatori specifici per l'impiego in applicazioni gravose in presenza di polveri e/o elevata umidità con Classe di Protezione IP55.

Su richiesta possono anche essere forniti con specifiche Classi di protezione.

### PROTECTION CLASS

This fan is specifically designed for moist and dusty environment and meets the dust-proof and water-proof parameters of IP55 protection standard; in addition, it can also meet a variety of specific water-protection requirement from customers.

### CLASSES DE PROTECTION

Des ventilateurs spécifiques sont disponibles pour une utilisation dans des applications pénibles en présence de poussière et/ou d'humidité élevée avec la Classe de Protection IP55.

Sur demande, ils peuvent également être fournis avec des Classes de protections spécifiques.

### VENTILATORI CON GIRANTE AL MAGNESIO

Grazie all'elevato coefficiente di trasferimento termico del magnesio, i ventilatori con girante in lega di Magnesio apportano una notevole diminuzione della temperatura all'interno del sistema di rotazione del ventilatore con il conseguente vantaggio di un significativo aumento della durata di vita del ventilatore stesso.

Disponibili in 24Vac, 110V, 220V, 380V, 110/220V dual, con funzione resistente alle alte temperature (H.T.R.) e con funzione schermata contro le scariche elettromagnetiche (E.M.C.)

### MAGNESIUM ALLOY IMPELLER

Easier heat-transfer function of magnesium alloy impeller can decrease the environmental temperature of the fan bearing effectively and prolong the life-span of fan.

Available in AC24V, 110V, 220V, 380V, dual-voltage 110/220V, high temperature resistant function (H.T.R.) and electro magnetic shield function (E.M.C.)

### VENTILATEURS HÉLICE EN MAGNESIUM

Grâce au coefficient élevé de déplacement thermique du magnésium, les ventilateurs avec hélice en Magnésium apportent une diminution considérable de la température à l'intérieur du système de rotation du ventilateur avec l'avantage conséquent d'une augmentation significative de la durée de vie du ventilateur même.

Disponibles en AC24V, 110V, 220V, 380V, deux tensions 110/220V, fonction résistante à haute température (H.T.R.) et fonction de bouclier de protection électromagnétique (E.M.C.)

## STRUTTURA DEL CODICE | Code structure | Structure du code

TIPO	TAGLIA	VELOCITÀ	TENSIONE	SISTEMA DI SUPPORTO	MATERIALE TELAIO	CONNESSIONE
Type Type	Size Taille	Speed Vitesse	Voltage Tension	Bearing System Système de support	Frame material Matériel du châssis	Connection Connexion
<b>VS</b>	<b>1238</b>	<b>X</b>	<b>A1</b>	<b>B</b>	<b>M</b>	<b>L</b>
	8025 = 80x80x25 8038 = 80x80x38 9225 = 92x92x25 9238 = 92x92x38 12025 = 120x120x25 1238 = 120x120x38 12738 = 127x127x38 1525 = 150x150x51 1606 = 160x160x65 1806 = 180x180x65 2072 = 208x208x72 17023 = 172x152x38 1725 = 172x150x51 1725/5 = 172x150x55 - Ø172x55 2206 = 222x60 2509 = 254x89	X = Extra H = Alta M = Media L = Bassa	A1 = 115 Volt A2 = 230 Volt	B = Cuscinetto a sfera	M = Magnesio	L = Cavetti T = Faston 2,8mm

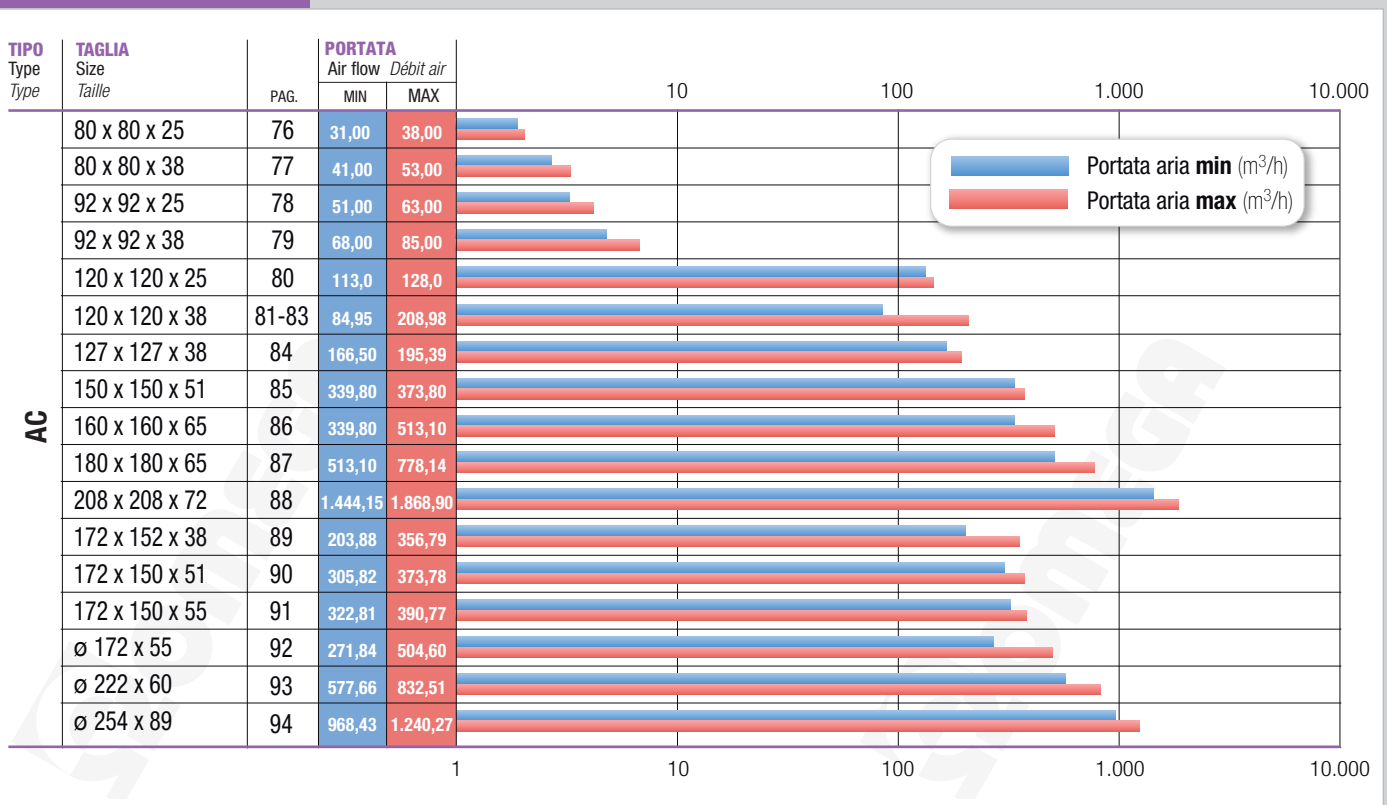
**INDICE PORTATA ARIA** Air flow index | *Index débit d'air*

Max m<sup>3</sup>/h 38

**AC FAN**  
**80x80x25**



Sistema di supporto	Bearing System	Système de support	Ball / Sleeve
Materiale telaio	Frame material	Matériel du chassis	Magnesium
Materiale pale	Blade material	Matériel des pâles	Thermoplastic UL94-V0
Numero pale	N. blade	Nombre de pâles	7
Connessione	Connection	Connexion	Faston / Lead wire
Temperatura di lavoro	Operating temperature	Température d'utilisation	-40°C + 70°C
Vita	Life	Vie	ball 60000 h 20 °C sleeve 50000 h 20 °C
Resistenza di isolamento	Insulation resistance	Résistance de l'isolement	More than 100 MΩ between internal stator and lead wires
Rigidità dielettrica	Dielectric strenght	Rigidité diélectrique	500Vac (1mA) for one minute or 600Vac for 1 second between housing and lead wires
Protezione	Protection	Protection	Impedance protected



60 pz  
60 pcs  
60 pces

Codice Code Code	Tensione Voltage Tension V	Frequenza Frequency Fréquence Hz	Corrente Current Courant A	Potenza Power Puissance W	Velocità Speed Vitesse RPM	Portata Aria Air Flow Débit d'air m <sup>3</sup> /h CFM	Pressione Pressure Pression mmH <sup>2</sup> O inchH <sup>2</sup> O	Rumore Noise Niveau sonore dbA	Peso Weight Poids g	Protezione blocco rotore Locked rotor protection Protection du bloc rotor
<b>Cuscinetti a sfera   Ball bearing   Roulement à billes</b>										
VS 8025 HA1 BMT	115	60	0,12	13	H 2700	38 22	3,80 0,15	32	210	Impedance
VS 8025 HA2 BMT	230	50	0,08	15	H 2300	31 18	3,00 0,12	30	210	Impedance



Disponibile anche in versione bronzina / Available also in sleeve bearing version / Disponible également en version à paliers lisses

**Portata Aria | Air Flow | Débit d'air**

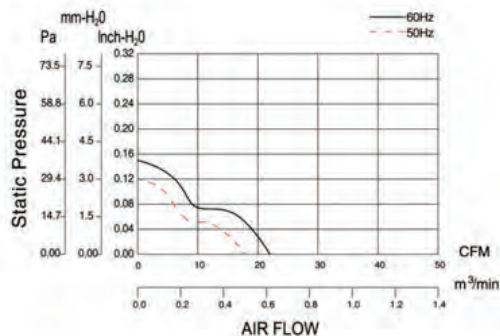

**Dimensioni | Dimensions | Dimensions**

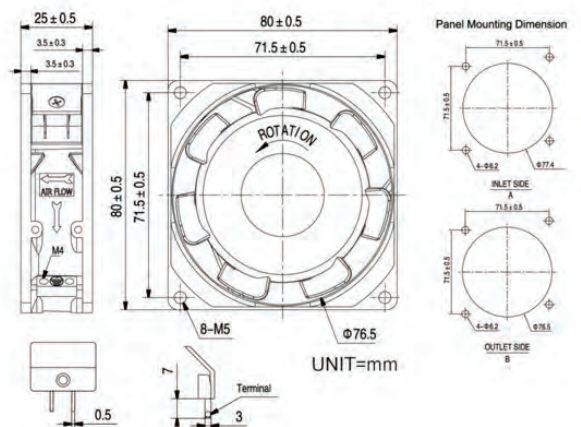

# AC FAN 80x80x38 mm

Max m<sup>3</sup>/h 53



Sistema di supporto	Bearing System	Système de support	Ball / Sleeve
Materiale telaio	Frame material	Matériel du chassis	Magnesium
Materiale pale	Blade material	Matériel des pâles	Thermoplastic UL94-V0
Numero pale	N. blade	Nombre de pâles	5
Connessione	Connection	Connexion	Faston / Lead wire
Temperatura di lavoro	Operating temperature	Température d'utilisation	-40°C + 70°C
Vita	Life	Vie	ball 60000 h 20 °C sleeve 50000 h 20 °C
Resistenza di isolamento	Insulation resistance	Résistance de l'isolement	More than 100 MΩ between internal stator and lead wires
Rigidità dielettrica	Dielectric strenght	Rigidité diélectrique	500Vac (1mA) for one minute or 600Vac for 1 second between housing and lead wires
Protezione	Protection	Protection	Impedance protected



40 pz  
40 pcs  
40 pces

Codice Code	Tensione Voltage Tension V	Frequenza Frequency Fréquence Hz	Corrente Current Courant A	Potenza Power Puissance W	Velocità Speed Vitesse RPM	Portata Aria Air Flow Débit d'air m <sup>3</sup> /h	CFM	Pressione Pressure Pression mmH <sup>2</sup> O	inchH <sup>2</sup> O	Rumore Noise Niveau sonore dbA	Peso Weight Poids g	Protezione blocco rotore Locked rotor protection Protection du bloc rotor
<b>Cuscinetti a sfera   Ball bearing   Roulement à billes</b>												
VS 8038 HA1 BML	115	60	0,13	13	H 2800	53	31	4,30	0,17	32	260	Impedance
VS 8038 HA2 BML	230	50	0,07	15	H 2300	41	24	3,30	0,13	30	260	Impedance



Disponibile anche in versione bronzina / Available also in sleeve bearing version / Disponible également en version à paliers lisses

## Portata Aria | Air Flow | Débit d'air

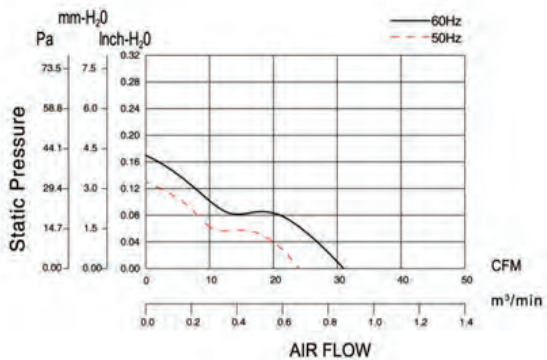

## Dimensioni | Dimensions | Dimensions

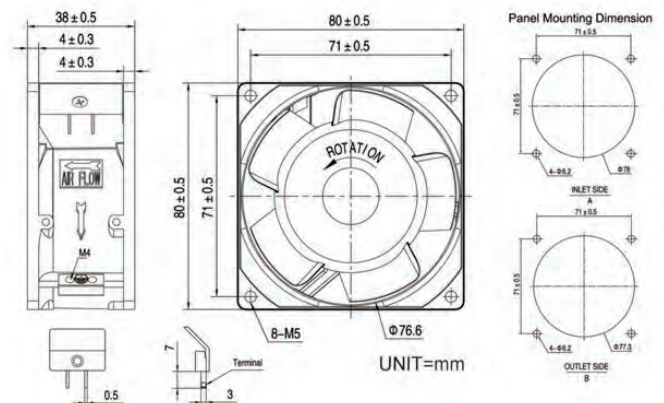

Max m<sup>3</sup>/h 63

**AC FAN**  
**92x92x25**



Sistema di supporto	Bearing System	Système de support	Ball / Sleeve
Materiale telaio	Frame material	Matériel du chassis	Magnesium
Materiale pale	Blade material	Matériel des pâles	Thermoplastic UL94-V0
Numero pale	N. blade	Nombre de pâles	7
Connessione	Connection	Connexion	Faston / Lead wire
Temperatura di lavoro	Operating temperature	Température d'utilisation	-40°C +70°C
Vita	Life	Vie	Ball 60.000 H 20°C/Sleeve 50.000 H 20°C
Resistenza di isolamento	Insulation resistance	Résistance de l'isolement	More than 100 MΩ between internal stator and lead wires
Rigidità dielettrica	Dielectric strenght	Rigidité diélectrique	500Vac (1mA) for one minute or 600Vac for 1 second between housing and lead wires
Protezione	Protection	Protection	Impedance protected



60 pz  
60 pcs  
60 pces

Codice Code Code	Tensione Voltage Tension V	Frequenza Frequency Fréquence Hz	Corrente Current Courant A	Potenza Power Puissance W	Velocità Speed Vitesse RPM	Portata Aria Air Flow Débit d'air m <sup>3</sup> /h CFM	Pressione Pressure Pression mmH <sup>2</sup> O inchH <sup>2</sup> O	Rumore Noise Niveau sonore dbA	Peso Weight Poids g	Protezione blocco rotore Locked rotor protection Protection du bloc rotor
<b>Cuscinetti a sfera   Ball bearing   Roulement à billes</b>										
VS 9225 HA1 BMT	115	60	0,15	16	H 2700	63 37	4,82 0,19	37	220	Impedance
VS 9225 HA2 BMT	230	50	0,08	17	H 2300	51 30	3,55 0,14	35	220	Impedance



Disponibile anche in versione bronzina / Available also in sleeve bearing version / Disponible également en version à paliers lisses

Portata Aria | Air Flow | Débit d'air

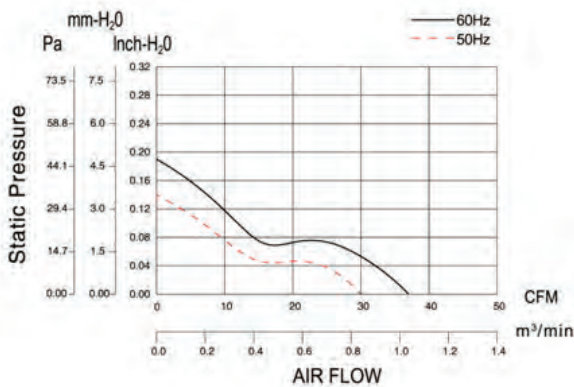

Dimensioni | Dimensions | Dimensions

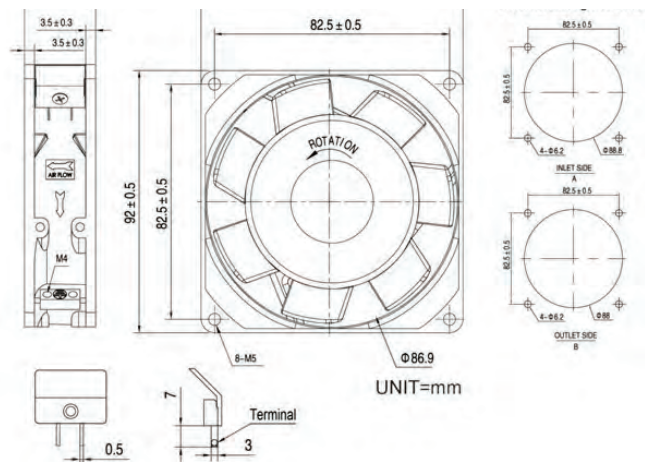

# AC FAN 92x92x38 mm

Max m<sup>3</sup>/h 85



Sistema di supporto	Bearing System	Système de support	Ball / Sleeve
Materiale telaio	Frame material	Matériel du chassis	Magnesium
Materiale pale	Blade material	Matériel des pâles	Thermoplastic UL94-V0
Numero pale	N. blade	Nombre de pâles	5
Connessione	Connection	Connexion	Faston / Lead wire
Temperatura di lavoro	Operating temperature	Température d'utilisation	-40°C + 70°C
Vita	Life	Vie	ball 60000 h 20 °C sleeve 50000 h 20 °C
Resistenza di isolamento	Insulation resistance	Résistance de l'isolement	More than 100 MΩ between internal stator and lead wires
Rigidità dielettrica	Dielectric strenght	Rigidité diélectrique	500Vac (1mA) for one minute or 600Vac for 1 second between housing and lead wires
Protezione	Protection	Protection	Impedance protected



40 pz  
40 pcs  
40 pces

Codice Code Code	Tensione Voltage Tension V	Frequenza Frequency Fréquence Hz	Corrente Current Courant A	Potenza Power Puissance W	Velocità Speed Vitesse RPM	Portata Aria Air Flow Débit d'air m <sup>3</sup> /h CFM	Pressione Pressure Pression mmH <sub>2</sub> O inchH <sub>2</sub> O	Rumore Noise Niveau sonore dbA	Peso Weight Poids g	Protezione blocco rotore Locked rotor protection Protection du bloc rotor
<b>Cuscinetti a sfera   Ball bearing   Roulement à billes</b>										
VS 9238 HA1 BMT	115	60	0,14	14	H 3000	85 50	6 0,24	41	330	Impedance
VS 9238 HA2 BMT	230	50	0,08	14	H 2500	68 40	4,5 0,18	37	330	Impedance



Disponibile anche in versione bronzina / Available also in sleeve bearing version / Disponible également en version à paliers lisses

Portata Aria | Air Flow | Débit d'air

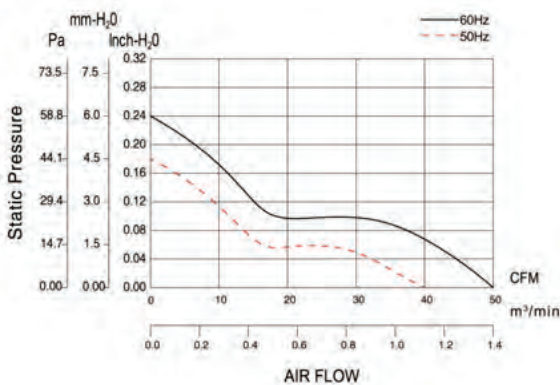

Dimensioni | Dimensions | Dimensions

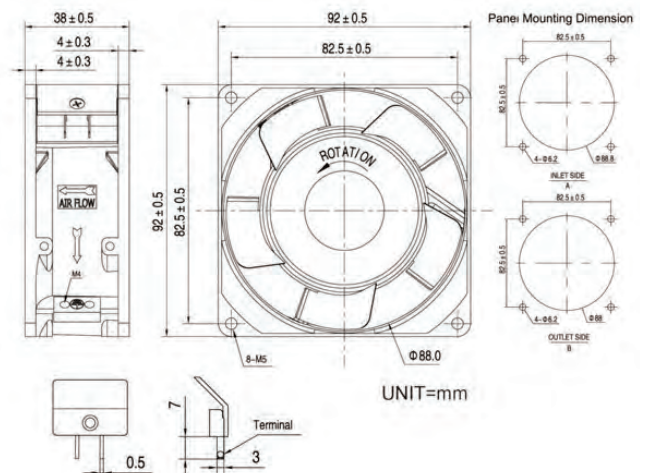



Max m<sup>3</sup>/h 120

**AC FAN**  
**120x120x25**



Sistema di supporto	Bearing System	Système de support	Ball / Sleeve
Materiale telaio	Frame material	Matériel du chassis	Magnesium alloy Mg
Materiale pale	Blade material	Matériel des pâles	Magnesium
Numero pale	N. blade	Nombre de pâles	5
Connessione	Connection	Connexion	Faston / Lead wire
Temperatura di lavoro	Operating temperature	Température d'utilisation	-40°C ~ + 80°C
Vita	Life	Vie	ball 50000 h 25 °C sleeve 30000 h 25 °C
Resistenza di isolamento	Insulation resistance	Résistance de l'isolement	More than 100 MΩ between internal stator and lead wires
Rigidità dielettrica	Dielectric strenght	Rigidité diélectrique	500Vac (1mA) for one minute or 600Vac for 1 second between housing and lead wires
Protezione	Protection	Protection	Impedance protected



Codice Code Code	Tensione Voltage Tension V	Frequenza Frequency Fréquence Hz	Corrente Current Courant A	Potenza Power Puissance W	Velocità Speed Vitesse RPM	Portata Aria Air Flow Débit d'air m <sup>3</sup> /h CFM	Pressione Pressure Pression mmH <sup>2</sup> O inchH <sup>2</sup> O	Rumore Noise Niveau sonore dbA	Peso Weight Poids g	Protezione blocco rotore Locked rotor protection Protection du bloc rotor
<b>Cuscinetti a sfera   Ball bearing   Roulement à billes</b>										
VS 1225 HA1 BMT	115	60	0,12	11	H 2200	120,6 71	4,064 0,16	38	320	Impedance
VS 1225 HA2 BMT	230	50	0,07	12	H 2100	110,4 65	3,556 0,13	44	320	Impedance



Disponibile anche in versione bronzina / Available also in sleeve bearing version / Disponible également en version à paliers lisses

Portata Aria | Air Flow | Débit d'air

Dimensioni | Dimensions | Dimensions

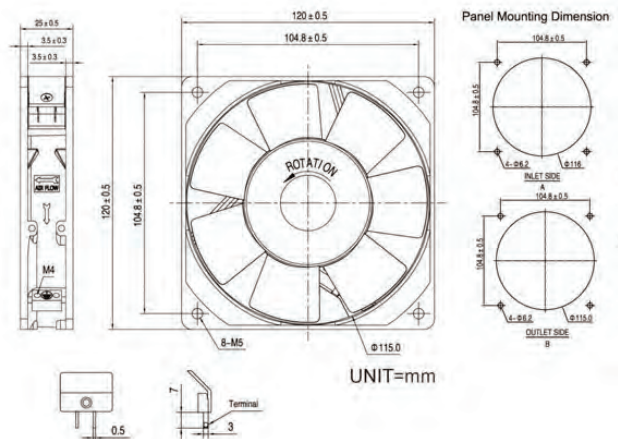
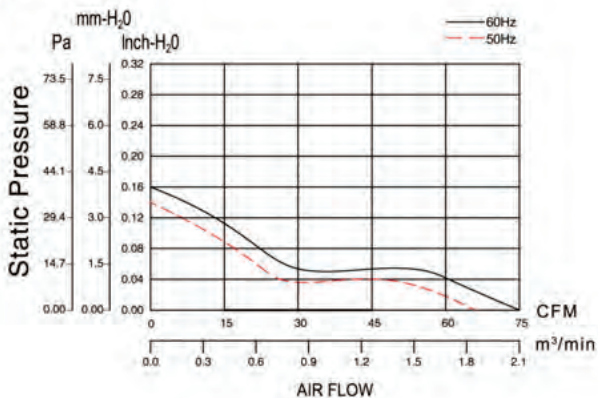

# AC FAN 120x120x38

Max m<sup>3</sup>/h 208,98



Sistema di supporto	Bearing System	Système de support	Ball bearing
Materiale telaio	Frame material	Matériel du chassis	Magnesium alloy Mg
Materiale pale	Blade material	Matériel des pâles	Magnesium
Numero pale	N. blade	Nombre de pâles	7
Connessione	Connection	Connexion	Faston / Lead wire
Temperatura di lavoro	Operating temperature	Température d'utilisation	-40°C ~ + 85°C
Vita	Life	Vie	ball 60000 h 20 °C
Resistenza di isolamento	Insulation resistance	Résistance de l'isolement	Min. 100 MΩ at 500 VDC between terminal and frame
Rigidità dielettrica	Dielectric strenght	Rigidité diélectrique	1800Vac for 2 seconds between terminal and frame
Grado di protezione	Sealing	Degré de Protection	IP55



40/1680 pz  
40/1680 pcs  
40/1680 pces

Codice Code Code	Tensione Voltage Tension V	Frequenza Frequency Fréquence Hz	Corrente Current Courant A	Potenza Power Puissance W	Velocità Speed Vitesse RPM	Portata Aria Air Flow Débit d'air m <sup>3</sup> /h CFM	Pressione Pressure Pression mmH <sub>2</sub> O inchH <sub>2</sub> O	Rumore Noise Niveau sonore dbA	Peso Weight Poids g	Protezione blocco rotore Locked rotor protection Protection du bloc rotor
<b>X Flow</b>										
VS 1238 XA1 BMT	115	60	0,25	20	X 2850	208,98 123	7,87 0,31	52	470	Impedance
VS 1238 XA2 BMT	230	50	0,15	23	X 2500	178,40 105	6,60 0,26	50	470	Impedance
<b>LL 4P</b>										
•VS 1238 LLA1BMT	115	60	0,13	8	LL 1500	93,45 55	1,77 0,07	38	470	Impedance
•VS 1238 LLA2BMT	230	50	0,09	10	LL 1300	84,95 50	1,52 0,06	36	470	Impedance

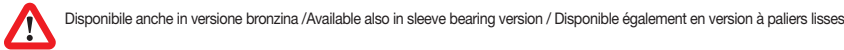

### Portata Aria | Air Flow | Débit d'air

### Dimensioni | Dimensions | Dimensions

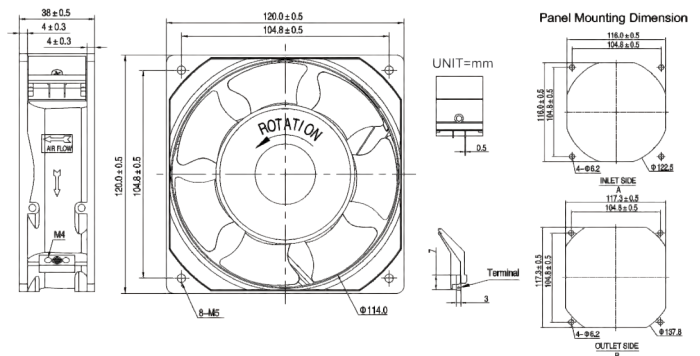
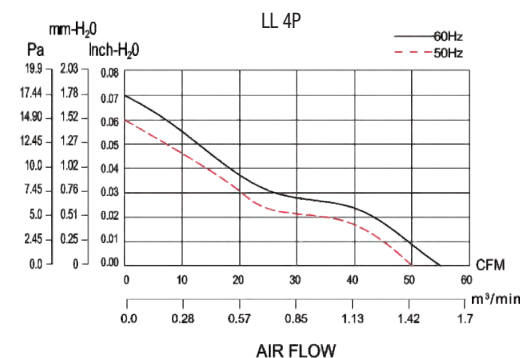
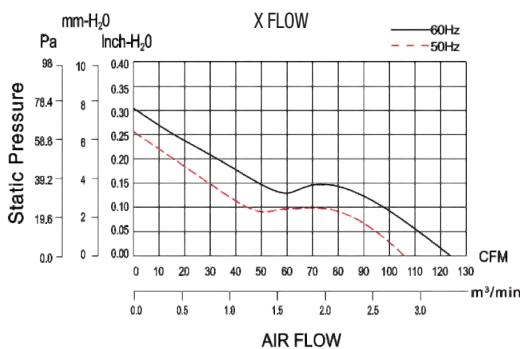

Max m<sup>3</sup>/h 169,90

## AC FAN 120x120x38



Sistema di supporto	Bearing System	Système de support	Ball bearing
Materiale telaio	Frame material	Matériel du chassis	Magnesium alloy Mg
Materiale pale	Blade material	Matériel des pâles	Magnesium alloy Mg
Numero pale	N. blade	Nombre de pâles	7
Connessione	Connection	Connexion	Faston / Lead wire
Temperatura di lavoro	Operating temperature	Température d'utilisation	-50°C ~ + 85°C
Vita	Life	Vie	ball 60000 h 20 °C
Resistenza di isolamento	Insulation resistance	Résistance de l'isolement	Min. 100 MΩ at 500 VDC between terminal and frame
Rigidità dielettrica	Dielectric strenght	Rigidité diélectrique	1800Vac for 2 seconds between terminal and frame
Grado di protezione	Sealing	Degré de Protection	IP55



40/1680 pz  
40/1680 pcs  
40/1680 pces

Code	Tensione Voltage Tension V	Frequenza Frequency Fréquence Hz	Corrente Current Courant A	Potenza Power Puissance W	Velocità Speed Vitesse RPM	Portata Aria Air Flow Débit d'air m <sup>3</sup> /h	Pressione Pressure Pression mmH <sup>2</sup> O	Rumore Noise Niveau sonore dbA	Peso Weight Poids g	Protezione blocco rotore Locked rotor protection Protection du bloc rotor		
<b>Velocità H / Speed H / Vitesse H</b>												
VS 1238 HA1 BMT	115	60	0,22	18	H 3100	169,90	100	8,63	0,34	51	460	Impedance
VS 1238 HA2 BMT	230	50	0,13	21	H 2700	142,72	84	7,11	0,28	49	460	Impedance
<b>Velocità M / Speed M / Vitesse M</b>												
VS 1238 MA1 BMT	115	60	0,12	11	M 2700	156,31	92	6,85	0,27	45	455	Impedance
VS 1238 MA2 BMT	230	50	0,08	14	M 2500	132,52	78	5,84	0,23	41	455	Impedance
<b>Velocità L / Speed L / Vitesse L</b>												
VS 1238 LA1 BMT	115	60	0,09	8	L 2000	110,44	65	3,30	0,13	36	450	Impedance
VS 1238 LA2 BMT	230	50	0,05	9	L 2300	118,93	70	4,57	0,18	39	450	Impedance

Portata Aria | Air Flow | Débit d'air

Dimensioni | Dimensions | Dimensions

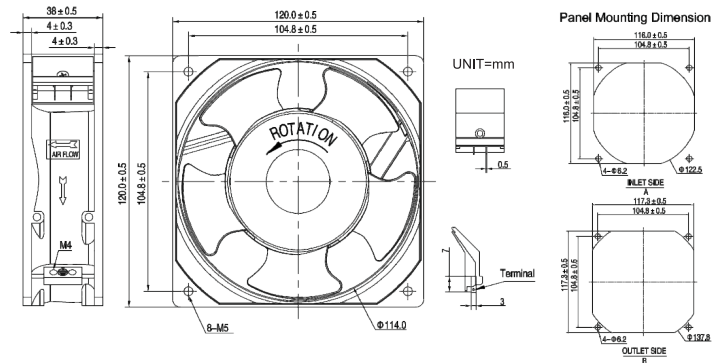
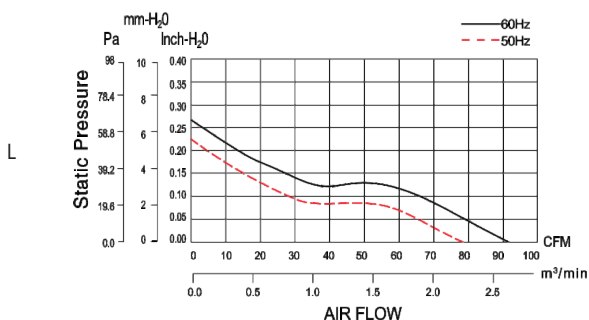
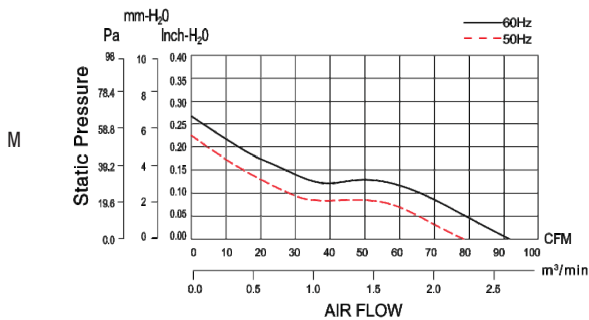
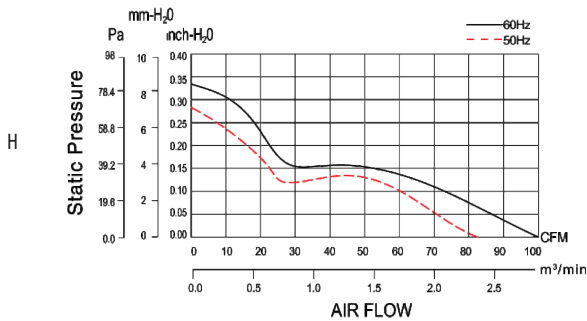

# AC FAN 120x120x38

Max m<sup>3</sup>/h 169,96



Sistema di supporto	Bearing System	Système de support	Ball bearing
Materiale telaio	Frame material	Matériel du chassis	Magnesium alloy Mg
Materiale pale	Blade material	Matériel des pâles	Magnesium alloy Mg
Numero pale	N. blade	Nombre de pâles	5
Connessione	Connection	Connexion	Faston / Lead wire
Temperatura di lavoro	Operating temperature	Température d'utilisation	-50°C ~ + 85°C
Vita	Life	Vie	ball 60000 h 20 °C
Resistenza di isolamento	Insulation resistance	Résistance de l'isolement	Min. 100 MΩ at 500 VDC between terminal and frame
Rigidità dielettrica	Dielectric strenght	Rigidité diélectrique	1800Vac for 2 seconds between terminal and frame
Grado di protezione	Sealing	Degré de Protection	IP55



40/1680 pz  
40/1680 pcs  
40/1680 pces

Codice Code	Tensione Voltage Tension V	Frequenza Frequency Fréquence Hz	Corrente Current Courant A	Potenza Power Puissance W	Velocità Speed Vitesse RPM	Portata Aria Air Flow Débit d'air m <sup>3</sup> /h	Pressione Pressure Pression mmH <sub>2</sub> O	Rumore Noise Niveau sonore dbA	Peso Weight Poids g	Protezione blocco rotore Locked rotor protection Protection du bloc rotor	
<b>24 Volt AC</b>											
VS 1238 HA24-2 BMT	24	50/60	1,05/0,85	15/13	H 2700/3100	142,72/169,96	84/100	7,11/8,63 0,28/0,34	45/51	460	Impedance
<b>Alta Temperatura 100°C / High temperature 100°C / Haute température 100°C</b>											
•VS 1238 HA1 HTR100 BML	115	60	0,20	16	H 3100	169,96	100	8,63 0,34	51	460	Impedance
•VS 1238 HA2 HTR100 BML	230	50	0,12	18	H 2700	142,72	84	7,11 0,28	49	460	Impedance
<b>Alta Temperatura 130°C / High temperature 130°C / Haute température 130°C</b>											
•VS 1238 HA1 HTR130 BML	115	60	0,20	16	H 3100	169,96	100	8,63 0,34	51	460	Impedance
•VS 1238 HA2 HTR130 BML	230	50	0,12	18	H 2700	142,72	84	7,11 0,28	49	460	Impedance



• Connessione: con filo  
Connection: lead wire  
Connexion: à fils

### Portata Aria | Air Flow | Débit d'air

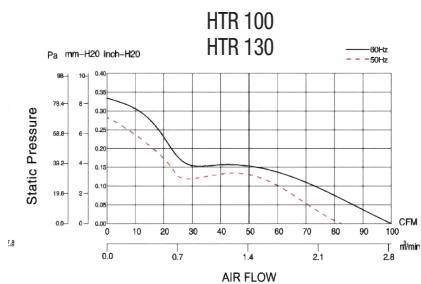
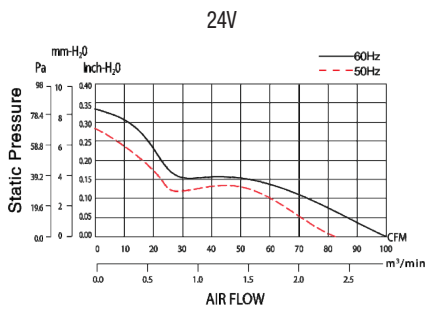

### Dimensioni | Dimensions | Dimensions

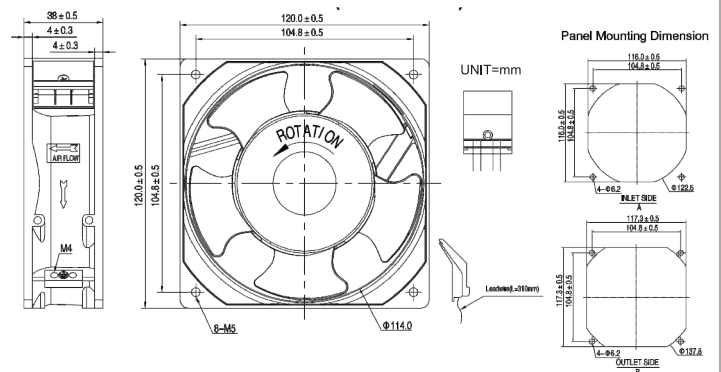

Max m<sup>3</sup>/h 195,39

## AC FAN 127x127x38



Sistema di supporto	Bearing System	Système de support	Ball bearing
Materiale telaio	Frame material	Matériel du chassis	Magnesium alloy Mg
Materiale pale	Blade material	Matériel des pâles	Polycarbonate PC
Numero pale	N. blade	Nombre de pâles	7
Connessione	Connection	Connexion	Faston / Lead wire
Temperatura di lavoro	Operating temperature	Température d'utilisation	-40°C ~ + 85°C
Vita	Life	Vie	ball 60000 h 20 °C
Resistenza di isolamento	Insulation resistance	Résistance de l'isolement	Min. 100 MΩ at 500 VDC between terminal and frame
Rigidità dielettrica	Dielectric strenght	Rigidité diélectrique	1800Vac for 2 seconds between terminal and frame
Grado di protezione	Sealing	Degré de Protection	IP55



40/1680 pz  
40/1680 pcs  
40/1680 pces

Codice Code Code	Tensione Voltage Tension V	Frequenza Frequency Fréquence Hz	Corrente Current Courant A	Potenza Power Puissance W	Velocità Speed Vitesse RPM	Portata Aria Air Flow Débit d'air m <sup>3</sup> /h CFM	Pressione Pressure Pression mmH <sub>2</sub> O inchH <sub>2</sub> O	Rumore Noise Niveau sonore dbA	Peso Weight Poids g	Protezione blocco rotore Locked rotor protection Protection du bloc rotor
VS 12738 HA1-2 BMT	115	60	0,22	18	H 3100	195,39 115	7,87 0,31	52	460	Impedance
VS 12738 HA2-2 BMT	230	50	0,13	21	H 2700	166,50 98	7,62 0,30	50	460	Impedance

Portata Aria | Air Flow | Débit d'air

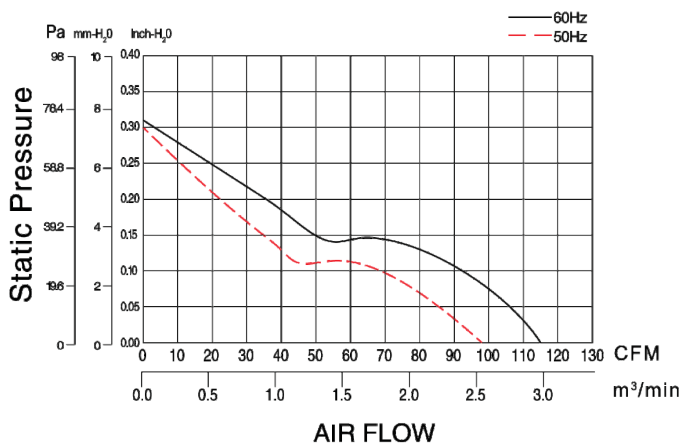

Dimensioni | Dimensions | Dimensions

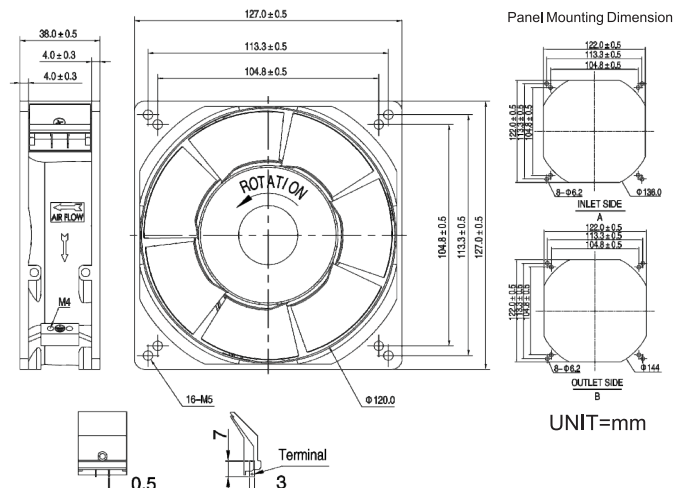

# AC FAN 150x150x51

Max m<sup>3</sup>/h 373,78



Sistema di supporto	Bearing System	Système de support	Ball bearing
Materiale telaio	Frame material	Matériel du chassis	Magnesium alloy Mg
Materiale pale	Blade material	Matériel des pâles	Magnesium alloy Mg
Numero pale	N. blade	Nombre de pâles	5
Connessione	Connection	Connexion	Faston / Lead wire
Temperatura di lavoro	Operating temperature	Température d'utilisation	-50°C ~ + 85°C
Vita	Life	Vie	ball 60000 h 20 °C
Resistenza di isolamento	Insulation resistance	Résistance de l'isolement	Min. 100 MΩ at 500 VDC between terminal and frame
Rigidità dielettrica	Dielectric strenght	Rigidité diélectrique	1800Vac for 2 seconds between terminal and frame
Grado di protezione	Sealing	Degré de Protection	IP55



40/1680 pz  
40/1680 pcs  
40/1680 pces

Codice Code	Tensione Voltage Tension V	Frequenza Frequency Fréquence Hz	Corrente Current Courant A	Potenza Power Puissance W	Velocità Speed Vitesse RPM	Portata Aria Air Flow Débit d'air m <sup>3</sup> /h CFM	Pressione Pressure Pression mmH <sub>2</sub> O inchH <sub>2</sub> O	Rumore Noise Niveau sonore dbA	Peso Weight Poids g	Protezione blocco rotore Locked rotor protection Protection du bloc rotor		
VS 1525 HA1-2 BMT	115	60	0,55	40	H 3200	373,78	220	15,20	0,60	59	990	Impedance
VS 1525 HA2-2 BMT	230	50	0,35	45	H 2800	339,80	200	12,95	0,51	57	990	Impedance

Portata Aria | Air Flow | Débit d'air

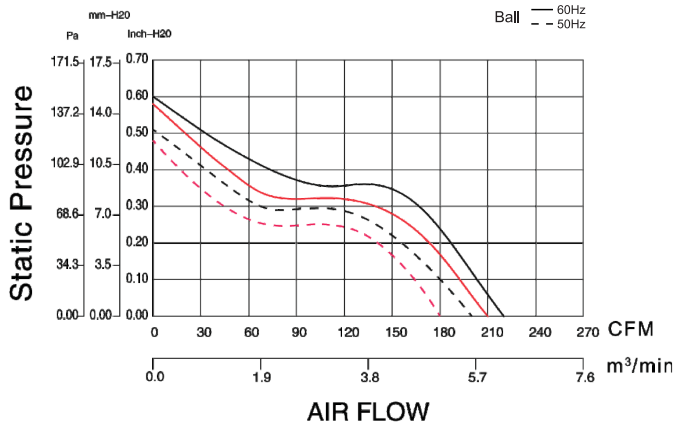

Dimensioni | Dimensions | Dimensions

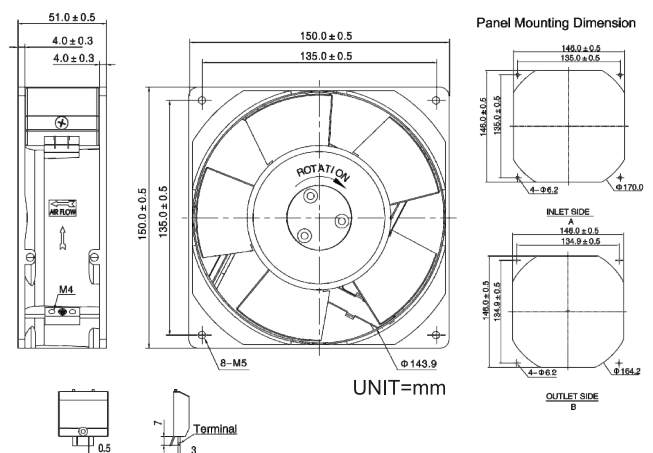

Max m<sup>3</sup>/h 513,10

## AC FAN 160x160x65



Sistema di supporto	Bearing System	Système de support	Ball bearing
Materiale telaio	Frame material	Matériel du chassis	Magnesium alloy Mg
Materiale pale	Blade material	Matériel des pâles	Polycarbonate PC
Numero pale	N. blade	Nombre de pâles	7
Connessione	Connection	Connexion	Faston / Lead wire
Temperatura di lavoro	Operating temperature	Température d'utilisation	-40°C ~ + 85°C
Vita	Life	Vie	ball 60000 h 20 °C
Resistenza di isolamento	Insulation resistance	Résistance de l'isolement	Min. 100 M $\Omega$ at 500 VDC between terminal and frame
Rigidità dielettrica	Dielectric strenght	Rigidité diélectrique	1800Vac for 2 seconds between terminal and frame



20/320 pz  
20/320 pcs  
20/320 pces

Code	Tensione Voltage Tension V	Frequenza Frequency Fréquence Hz	Corrente Current Courant A	Potenza Power Puissance W	Velocità Speed Vitesse RPM	Portata Aria Air Flow Débit d'air m <sup>3</sup> /h CFM		Pressione Pressure Pression mmH <sup>2</sup> O inchH <sup>2</sup> O		Rumore Noise Niveau sonore dbA	Peso Weight Poids g	Protezione blocco rotore Locked rotor protection Protection du bloc rotor
VS 1606 HA1-2 BMT	115	60	0,31	36	H 3300	513,10	302	16,51	0,65	63	1130	Thermal
VS 1606 HA2-2 BMT	230	50	0,12	27	H 2800	440,04	259	14,73	0,58	59	1130	Thermal

Portata Aria | Air Flow | Débit d'air

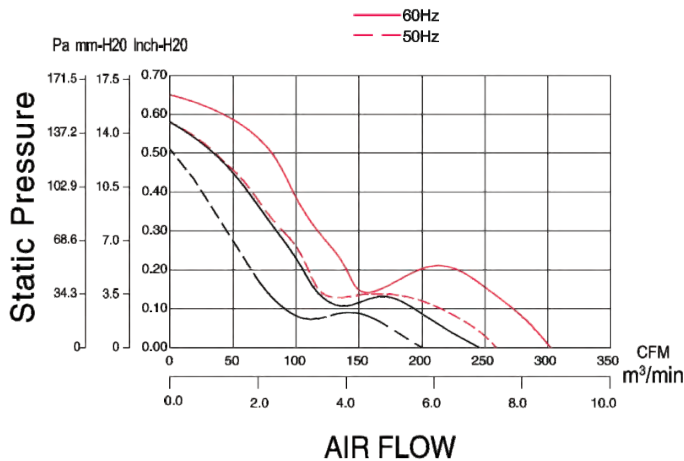

Dimensioni | Dimensions | Dimensions

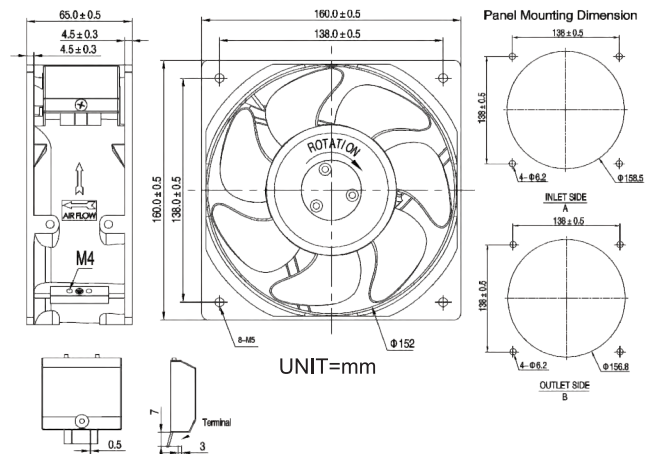

# AC FAN 180x180x65

Max m<sup>3</sup>/h 778,14



Sistema di supporto	Bearing System	Système de support	Ball bearing
Materiale telaio	Frame material	Matériel du chassis	Magnesium alloy Mg
Materiale pale	Blade material	Matériel des pâles	Polycarbonate PC
Numero pale	N. blade	Nombre de pâles	7
Connessione	Connection	Connexion	Faston / Lead wire
Temperatura di lavoro	Operating temperature	Température d'utilisation	-40°C ~ + 85°C
Vita	Life	Vie	ball 60000 h 20 °C
Resistenza di isolamento	Insulation resistance	Résistance de l'isolement	Min. 100 M $\Omega$ at 500 VDC between terminal and frame
Rigidità dielettrica	Dielectric strenght	Rigidité diélectrique	1800Vac for 2 seconds between terminal and frame



10/160 pz  
10/160 pcs  
10/160 pces

Code	Tensione Voltage Tension V	Frequenza Frequency Fréquence Hz	Corrente Current Courant A	Potenza Power Puissance W	Velocità Speed Vitesse RPM	Portata Aria Air Flow Débit d'air m <sup>3</sup> /h	Pressione Pressure Pression mmH <sup>2</sup> O	Rumore Noise Niveau sonore dbA	Peso Weight Poids g	Protezione blocco rotore Locked rotor protection Protection du bloc rotor
VS 1806 HA1-2 BMT	115	60	0,51	58	H 3200	778,14	24,13	65	1450	Thermal
VS 1806 HA2-2 BMT	230	50	0,26	55	H 2800	677,90	18,28	61	1450	Thermal

Portata Aria | Air Flow | Débit d'air

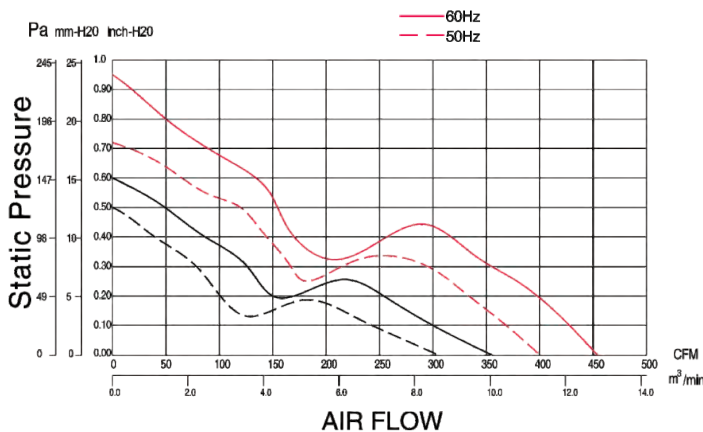

Dimensioni | Dimensions | Dimensions

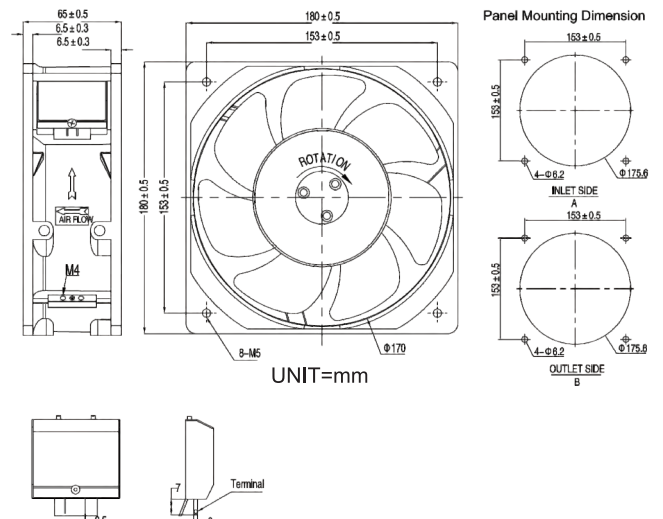



Max m<sup>3</sup>/h 1868,90

## AC FAN 208x208x72



Sistema di supporto	Bearing System	Système de support	<b>Ball bearing</b>
Materiale telaio	Frame material	Matériel du chassis	<b>Magnesium alloy Mg</b>
Materiale pale	Blade material	Matériel des pâles	<b>Magnesium alloy Mg</b>
Numero pale	N. blade	Nombre de pâles	<b>7</b>
Connessione	Connection	Connexion	<b>Faston / Lead wire</b>
Temperatura di lavoro	Operating temperature	Température d'utilisation	<b>-50°C ~ + 85°C</b>
Vita	Life	Vie	<b>ball 60000 h 20 °C</b>
Resistenza di isolamento	Insulation resistance	Résistance de l'isolement	<b>Min. 100 MΩ at 500 VDC between terminal and frame</b>
Rigidità dielettrica	Dielectric strenght	Rigidité diélectrique	<b>1800Vac for 2 seconds between terminal and frame</b>



8/192 pz  
8/192 pcs  
8/192 pces

Codice Code Code	Tensione Voltage Tension V	Frequenza Frequency Fréquence Hz	Corrente Current Courant A	Potenza Power Puissance W	Velocità Speed Vitesse RPM	Portata Aria Air Flow Débit d'air m <sup>3</sup> /h CFM	Pressione Pressure Pression mmH <sub>2</sub> O inchH <sub>2</sub> O	Rumore Noise Niveau sonore dbA	Peso Weight Poids g	Protezione blocco rotore Locked rotor protection Protection du bloc rotor
<b>H</b> VS 2072 HA1-2 BMT	115	60	0,90	115	H 3400	1868,90 1100	19,81 0,78	74	2250	Thermal

Portata Aria | Air Flow | Débit d'air

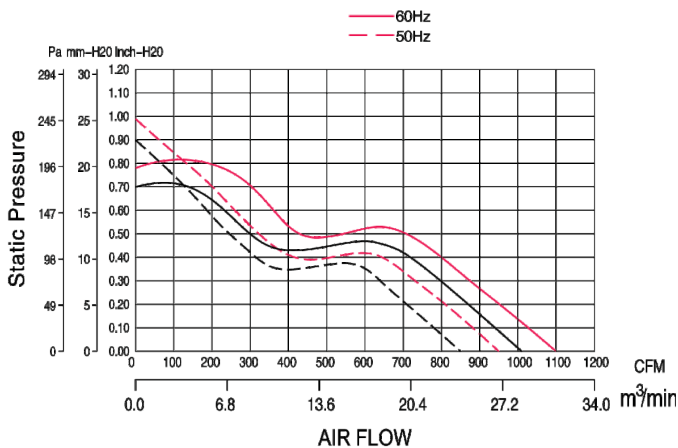

Dimensioni | Dimensions | Dimensions

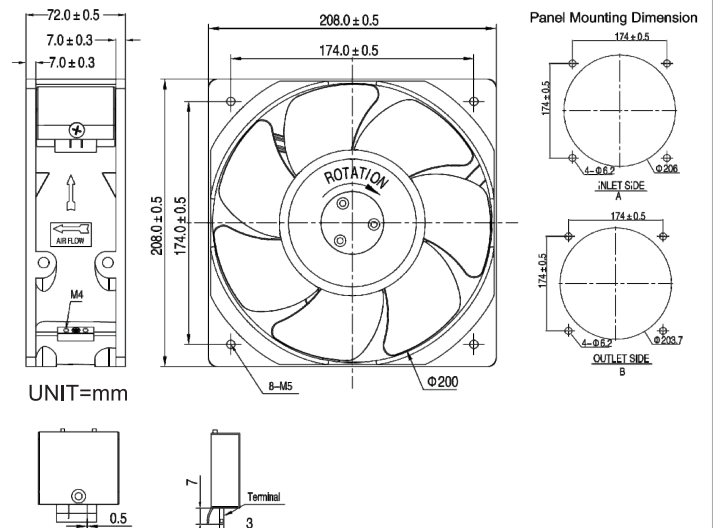

# AC FAN 172x152x38

Max m<sup>3</sup>/h 356,79



Sistema di supporto	Bearing System	Système de support	Ball bearing
Materiale telaio	Frame material	Matériel du chassis	Magnesium alloy Mg
Materiale pale	Blade material	Matériel des pâles	Magnesium alloy Mg
Numero pale	N. blade	Nombre de pâles	7
Connessione	Connection	Connexion	Faston / Lead wire
Temperatura di lavoro	Operating temperature	Température d'utilisation	-50°C ~ + 85°C
Vita	Life	Vie	ball 60000 h 20 °C
Resistenza di isolamento	Insulation resistance	Résistance de l'isolement	Min. 100 MΩ at 500 VDC between terminal and frame
Rigidità dielettrica	Dielectric strenght	Rigidité diélectrique	1800Vac for 2 seconds between terminal and frame
Grado di protezione	Sealing	Degré de Protection	IP55



20/320 pz  
20/320 pcs  
20/320 pces

Codice Code	Tensione Voltage Tension V	Frequenza Frequency Fréquence Hz	Corrente Current Courant A	Potenza Power Puissance W	Velocità Speed Vitesse RPM	Portata Aria Air Flow Débit d'air m <sup>3</sup> /h CFM	Pressione Pressure Pression mmH <sup>2</sup> O inchH <sup>2</sup> O	Rumore Noise Niveau sonore dbA	Peso Weight Poids g	Protezione blocco rotore Locked rotor protection Protection du bloc rotor
VS 17023 HA1-2 BMT	115	60	0,23	26	H 3300	356,79 210	21,00 0,83	61	700	Thermal
VS 17023 HA2-2 BMT	230	50	0,13	27	H 2800	305,82 180	15,74 0,62	57	700	Thermal

Portata Aria | Air Flow | Débit d'air

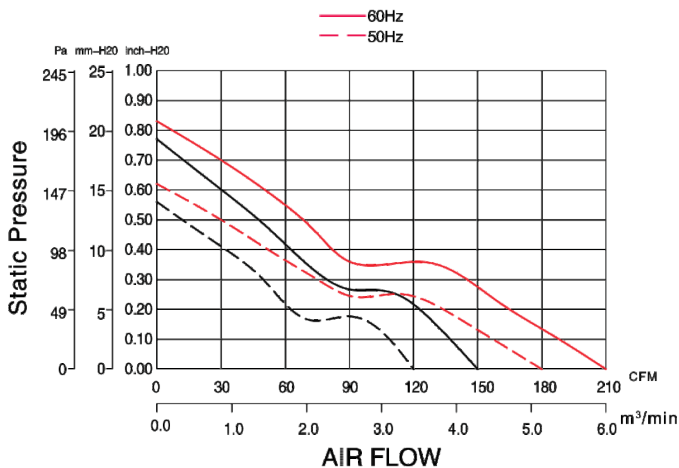

Dimensioni | Dimensions | Dimensions

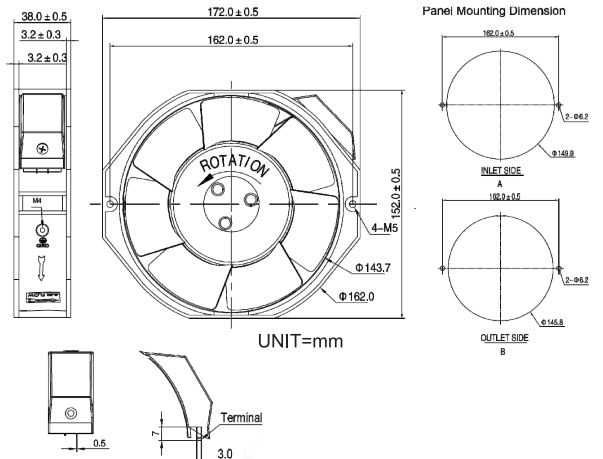

Max m<sup>3</sup>/h 373,78

## AC FAN 172x150x51



Sistema di supporto	Bearing System	Système de support	Ball bearing
Materiale telaio	Frame material	Matériel du chassis	Magnesium alloy Mg
Materiale pale	Blade material	Matériel des pâles	Magnesium alloy Mg
Numero pale	N. blade	Nombre de pâles	5
Connessione	Connection	Connexion	Faston / Lead wire
Temperatura di lavoro	Operating temperature	Température d'utilisation	-50°C ~ + 85°C
Vita	Life	Vie	ball 60000 h 20 °C
Resistenza di isolamento	Insulation resistance	Résistance de l'isolement	Min. 100 MΩ at 500 VDC between terminal and frame
Rigidità dielettrica	Dielectric strenght	Rigidité diélectrique	1800Vac for 2 seconds between terminal and frame
Grado di protezione	Sealing	Degré de Protection	IP55



24/576 pz  
24/576 pcs  
24/576 pces

Codice Code Code	Tensione Voltage Tension V	Frequenza Frequency Fréquence Hz	Corrente Current Courant A	Potenza Power Puissance W	Velocità Speed Vitesse RPM	Portata Aria Air Flow Débit d'air m <sup>3</sup> /h	CFM	Pressione Pressure Pression mmH <sup>2</sup> O	inchH <sup>2</sup> O	Rumore Noise Niveau sonore dbA	Peso Weight Poids g	Protezione blocco rotore Locked rotor protection Protection du bloc rotor
<b>H</b>												
VS 1725 HA1-2 BMT	115	60	0,55	40	H 3200	373,78	220	15,64	0,60	59	940	Impedance
VS 1725 HA2-2 BMT	230	50	0,35	45	H 2800	339,80	200	12,95	0,51	57	940	Impedance
<b>AC 24 V</b>												
○ VS 1725 HA24 BMT	24	50/60	2,40/2,00	45/40	H 2800/3200	339,80/373,78	200/220	12,95/15,64	0,51/0,60	57/59	940	Impedance



• Disponibile versione a 380 V  
Available 380 V  
Disponible en 380 V



○ Non omologato  
Not approved  
Non homologué



### Portata Aria | Air Flow | Débit d'air

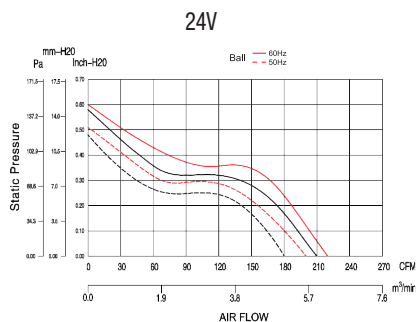
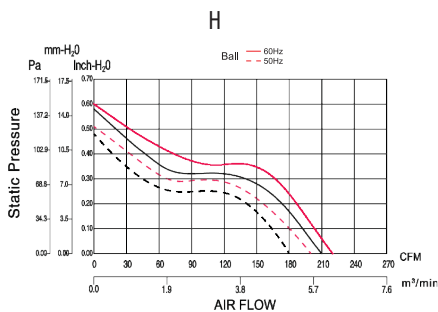

### Dimensioni | Dimensions | Dimensions

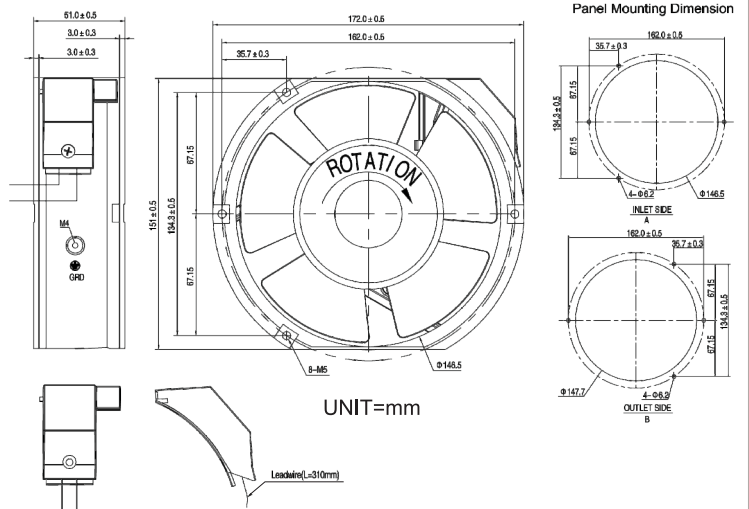

# AC FAN 172x150x55

Max m<sup>3</sup>/h 390,77



Sistema di supporto	Bearing System	Système de support	Ball bearing
Materiale telaio	Frame material	Matériel du chassis	Magnesium alloy Mg
Materiale pale	Blade material	Matériel des pâles	Magnesium alloy Mg
Numero pale	N. blade	Nombre de pâles	5 - 7
Connessione	Connection	Connexion	Faston / Lead wire
Temperatura di lavoro	Operating temperature	Température d'utilisation	-50°C ~ + 85°C
Vita	Life	Vie	ball 60000 h 20 °C
Resistenza di isolamento	Insulation resistance	Résistance de l'isolement	Min. 100 MΩ at 500 VDC between terminal and frame
Rigidità dielettrica	Dielectric strenght	Rigidité diélectrique	1800Vac for 2 seconds between terminal and frame
Grado di protezione	Sealing	Degré de Protection	IP55

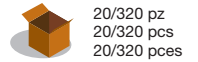

Code	Tensione Voltage Tension V	Frequenza Frequency Fréquence Hz	Corrente Current Courant A	Potenza Power Puissance W	Velocità Speed Vitesse RPM	Portata Aria Air Flow Débit d'air m <sup>3</sup> /h	CFM	Pressione Pressure Pression mmH <sup>2</sup> O	inchH <sup>2</sup> O	Rumore Noise Niveau sonore dbA	Peso Weight Poids g	Protezione blocco rotore Locked rotor protection Protection du bloc rotor
<b>5 Pale   5 Blades   5 Pâles</b>												
VS 1725/5 BHA1-2 BML	115	60	0,44	42	H 2900	390,77	230	11,94	0,47	60	980	Thermal
VS 1725/5 BHA2-2 BML	230	50	0,28	45	H 2600	356,79	210	11,43	0,45	58	980	Thermal
<b>7 Pale   7 Blades   7 Pâles</b>												
VS 1725/5 CHA1-2 BML	115	60	0,44	42	H 2900	356,79	210	15,74	0,62	58	960	Thermal
VS 1725/5 CHA2-2 BML	230	50	0,28	45	H 2600	322,81	190	13,97	0,55	55	960	Thermal

Portata Aria | Air Flow | Débit d'air

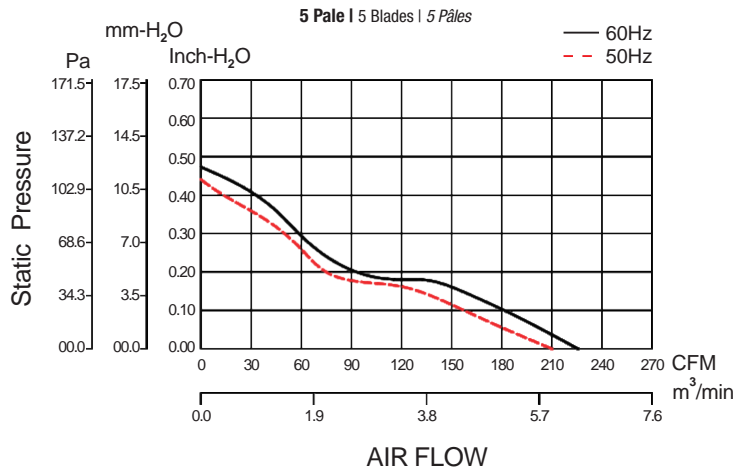

Dimensioni | Dimensions | Dimensions

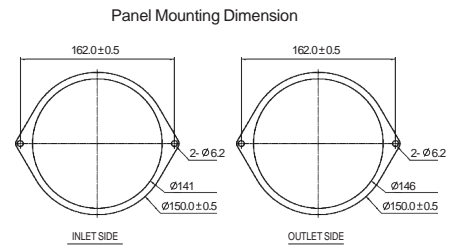
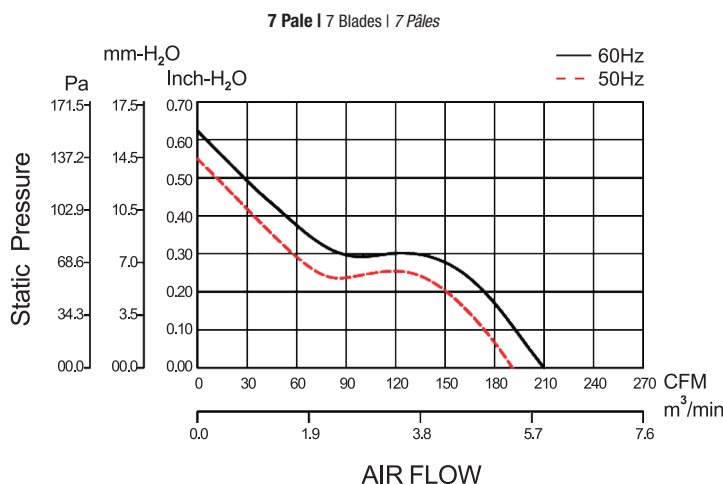
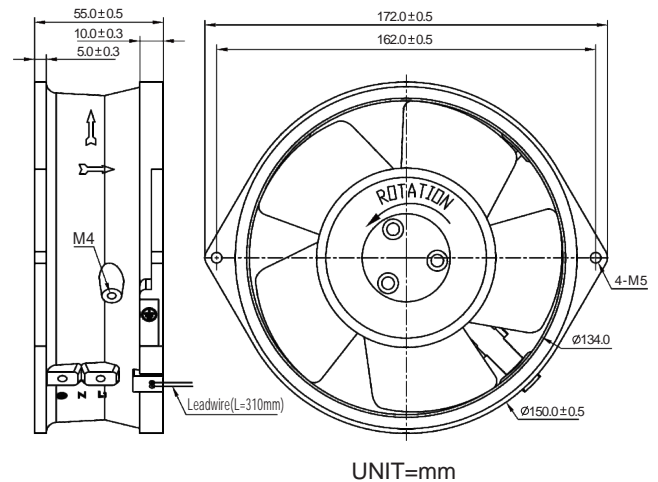

Max m<sup>3</sup>/h 504,60

**AC FAN**  
**172x55**



Sistema di supporto	Bearing System	Système de support	<b>Ball bearing</b>
Materiale telaio	Frame material	Matériel du chassis	<b>Magnesium alloy Mg</b>
Materiale pale	Blade material	Matériel des pâles	<b>Polycarbonate PC</b>
Numero pale	N. blade	Nombre de pâles	<b>5</b>
Connessione	Connection	Connexion	<b>Faston / Lead wire</b>
Temperatura di lavoro	Operating temperature	Température d'utilisation	<b>-40°C ~ + 85°C</b>
Vita	Life	Vie	<b>ball 60000 h 20 °C</b>
Resistenza di isolamento	Insulation resistance	Résistance de l'isolement	<b>Min. 100 MΩ at 500 VDC between terminal and frame</b>
Rigidità dielettrica	Dielectric strenght	Rigidité diélectrique	<b>1800Vac for 2 seconds between terminal and frame</b>
Grado di protezione	Sealing	Degré de Protection	<b>IP55</b>



20/320 pz  
20/320 pcs  
20/320 pces

Codice Code Code	Tensione Voltage Tension V	Frequenza Frequency Fréquence Hz	Corrente Current Courant A	Potenza Power Puissance W	Velocità Speed Vitesse RPM	Portata Aria Air Flow Débit d'air m <sup>3</sup> /h CFM	Pressione Pressure Pression mmH <sup>2</sup> O inchH <sup>2</sup> O	Rumore Noise Niveau sonore dbA	Peso Weight Poids g	Protezione blocco rotore Locked rotor protection Protection du bloc rotor		
VS 1725/5 HA1 BMT	115	60	0,30	34	H 3300	504,60	297	25,40	1,00	64	1000	Thermal
VS 1725/5 HA2 BMT	230	50	0,12	25	H 2800	424,75	250	19,55	0,77	60	1000	Thermal

Portata Aria | Air Flow | Débit d'air

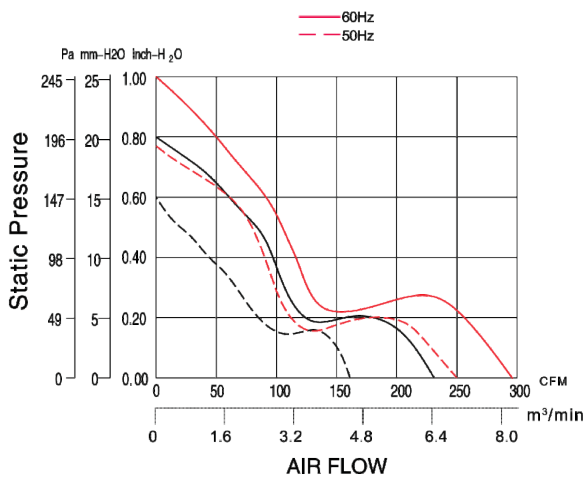

Dimensioni | Dimensions | Dimensions

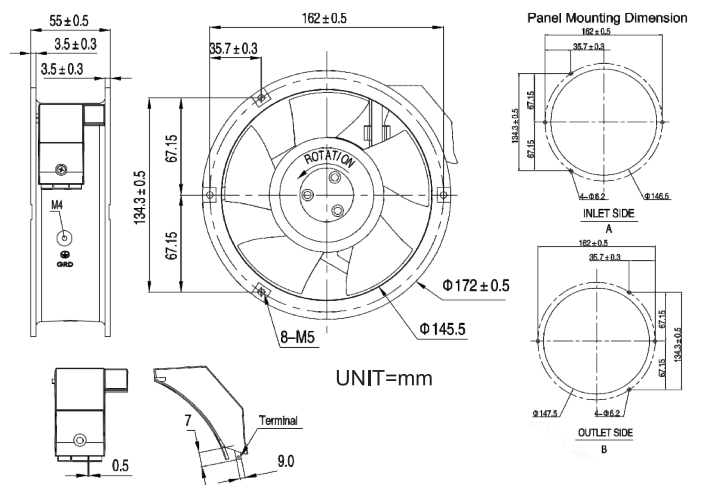

# AC FAN 222x60

Max m<sup>3</sup>/h 832,51



Sistema di supporto	Bearing System	Système de support	Ball bearing
Materiale telaio	Frame material	Matériel du chassis	Magnesium alloy Mg
Materiale pale	Blade material	Matériel des pâles	Magnesium alloy Mg
Numero pale	N. blade	Nombre de pâles	5
Connessione	Connection	Connexion	Faston / Lead wire
Temperatura di lavoro	Operating temperature	Température d'utilisation	-50°C ~ + 85°C
Vita	Life	Vie	ball 60000 h 20 °C
Resistenza di isolamento	Insulation resistance	Résistance de l'isolement	Min. 100 MΩ at 500 VDC between terminal and frame
Rigidità dielettrica	Dielectric strenght	Rigidité diélectrique	1800Vac for 2 seconds between terminal and frame
Grado di protezione	Sealing	Degré de Protection	IP55



10/240 pz  
10/240 pcs  
10/240 pces

Codice Code	Tensione Voltage Tension V	Frequenza Frequency Fréquence Hz	Corrente Current Courant A	Potenza Power Puissance W	Velocità Speed Vitesse RPM	Portata Aria Air Flow Débit d'air m <sup>3</sup> /h	Pressione Pressure Pression mmH <sup>2</sup> O	Rumore Noise Niveau sonore dbA	Peso Weight Poids g	Protezione blocco rotore Locked rotor protection Protection du bloc rotor		
VS 2206 HA1-2 BMT	115	60	0,43	48	H 3300	832,51	490	16,51	0,65	68	1220	Thermal
VS 2206 HA2-2 BMT	230	50	0,26	54	H 2800	825,83	486	19,81	0,65	63	1200	Thermal

Portata Aria | Air Flow | Débit d'air

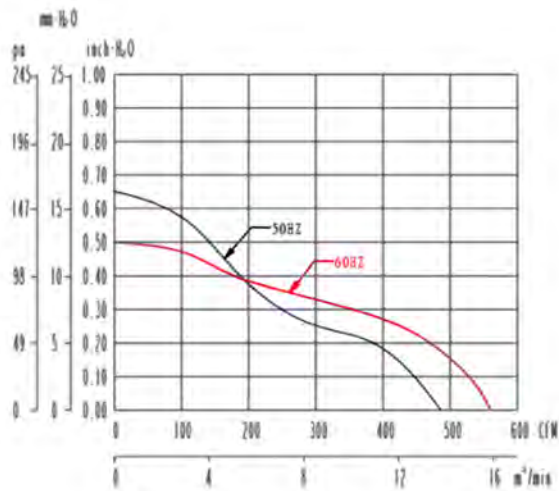

Dimensioni | Dimensions | Dimensions

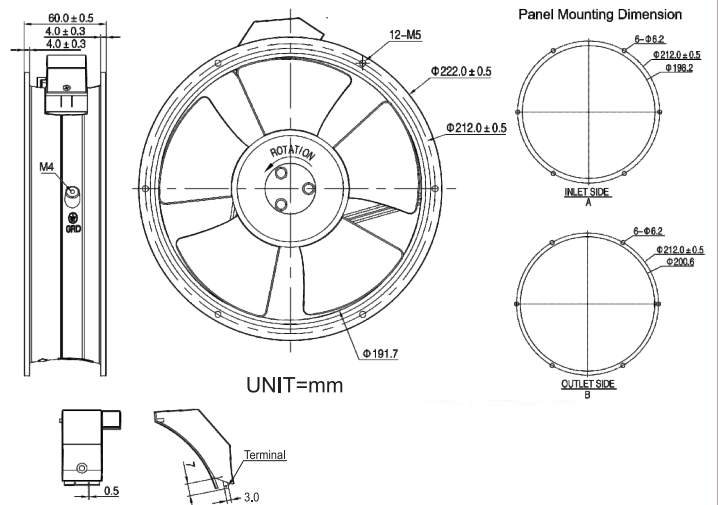

Max m<sup>3</sup>/h 1240,27

**AC FAN  
254x89**



Sistema di supporto	Bearing System	Système de support	Ball bearing
Materiale telaio	Frame material	Matériel du chassis	Magnesium alloy Mg
Materiale pale	Blade material	Matériel des pâles	Magnesium alloy Mg
Numero pale	N. blade	Nombre de pâles	5
Connessione	Connection	Connexion	Faston / Lead wire
Temperatura di lavoro	Operating temperature	Température d'utilisation	-50°C ~ + 85°C
Vita	Life	Vie	ball 60000 h 20 °C
Resistenza di isolamento	Insulation resistance	Résistance de l'isolement	Min. 100 MΩ at 500 VDC between terminal and frame
Rigidità dielettrica	Dielectric strenght	Rigidité diélectrique	1800Vac for 2 seconds between terminal and frame
Grado di protezione	Sealing	Degré de Protection	IP55



8/144 pz  
8/144 pcs  
8/144 pces

Codice Code	Tensione Voltage Tension V	Frequenza Frequency Fréquence Hz	Corrente Current Courant A	Potenza Power Puissance W	Velocità Speed Vitesse RPM	Portata Aria Air Flow Débit d'air m <sup>3</sup> /h	Pressione Pressure Pression mmH <sup>2</sup> O	Rumore Noise Niveau sonore dB(A)	Peso Weight Poids g	Protezione blocco rotore Locked rotor protection Protection du bloc rotor		
VS 2509 HA1-2 BMT	115	60	0,56	63	H 2600	1240,27	730	10,16	0,40	67	1940	Thermal
VS 2509 HA2-2 BMT	230	50	0,22	50	H 2500	1131,53	666	11,93	0,47	66	1940	Thermal

Portata Aria | Air Flow | Débit d'air

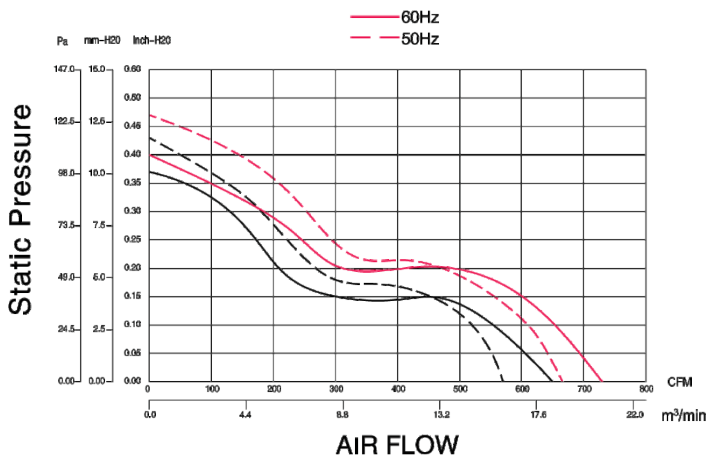

Dimensioni | Dimensions | Dimensions

